

ACE EQUIPMENT COMPANY



A-2/A-3

STATIONARY COMPACTORS

PROFESSIONALLY DESIGNED FOR: INDUSTRIAL - COMMERCIAL - MUNICIPAL - RECYCLING APPLICATIONS



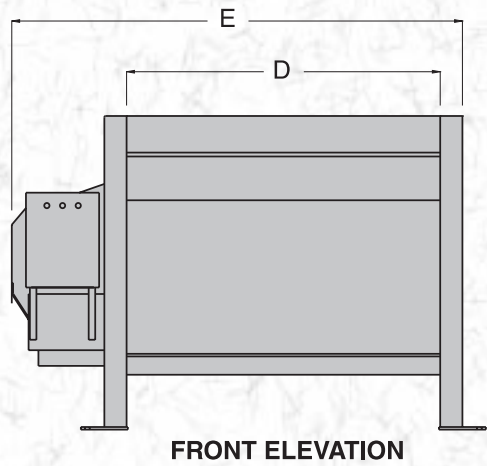
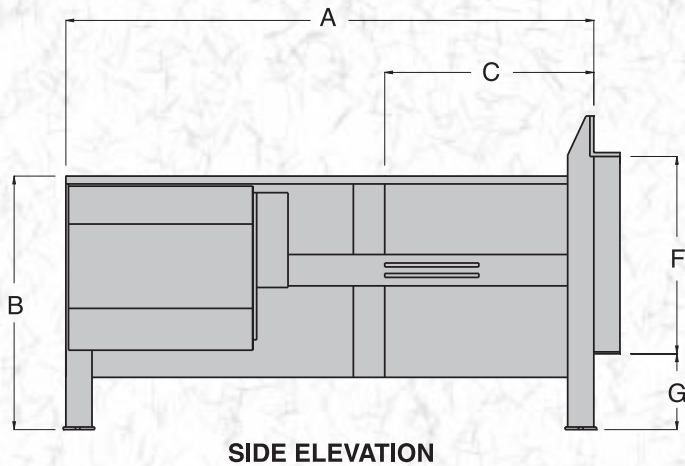

DIMENSIONS							
	A	B	C	D	E	F	G
A-2	94-1/4"	48-5/8"	45-1/4"	60"	86"	38-1/2"	14-1/2"
A-3	149-1/2"	48-5/8"	72"	60"	86"	38-1/2"	14-1/2"

PHYSICAL DIMENSIONS IN INCHES

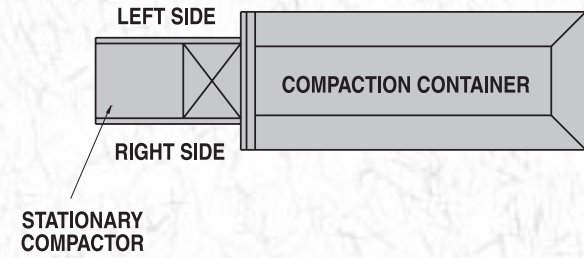

Features & Benefits

- ◆ The power unit mounted on either side for safe and easy maintenance.
- ◆ Key operated controls means only authorized personnel can operate the compactor.
- ◆ A full 15" of ram penetration for better compaction.
- ◆ The breaker bar is mounted above the compactor, therefore less packing resistant and create better compaction force.
- ◆ The shorter length allows it to be user friendly, and outperform in chute installations or room constraint installation.
- ◆ The compactors are built in a fixture to assure consistent and accurate construction every time.
- ◆ The ram bottom is 1/2" abrasion resistant steel for long life of the equipment.
- ◆ The ram face is 1/2" plate backed with structural channels.
- ◆ The floor is built for heavy demands, 1/2" plate backed with heavy 4" structural channels.

Optional Equipment:

- ◆ Cart dumper systems
- ◆ Multiple cycles
- ◆ Full and advance warning lights
- ◆ Remote controls
- ◆ Oil heaters
- ◆ Custom chutes
- ◆ Custom enclosures
- ◆ Many others available

Specifications

	A-2	A-3
Charge Box Capacity MFRS. Rating	2 Cu. Yds.	3 Cu. Yds.
Clear Top Opening	60" x 40-1/4"	60" x 67"

Structural Specifications

	A-2	A-3
Charge Box Sides	1/4"	1/4"
Charge Box Floor	1/2"	1/2"
Ram Face Plate	1/2"	1/2"
Ram Bottom	1/2" A.R.	1/2" A.R.

Electrical

Electric Motor	10 HP	10 HP
3 Phase / 60 HZ. / 208-230 / 460 VAC		
STANDARD CONTROLS: Keylock, Start, Stop, Reverse		

Performance

Cycle Time:	49 Sec	74 Sec
Maximum Force	62,800 Lbs.	62,800Lbs.
Ram Penetration	15"	15"
Weight	4600 Lbs.	5800 Lbs.



ACE Equipment Company
2843 County Road Y
Aniwa, WI 54408
(715) 449-3117

LEASING PROGRAM AVAILABLE