

# SELF-CONTAINED COMPACTORS

## Three Models and Various Sizes Available



## Uncompromising Quality from Day One

All Ace Equipment Company Self-Contained Compactors begin with 100% laser-cut components combined with slot and tab construction for repeatable quality and tolerances that no other manufacturer can offer. We combine this with an American-designed / American manufactured power unit. The Ace Equipment Company Self-Contained compactors feature American-made cylinders, free from tariffs and supply chain interruptions. The functionality of our compactors is enhanced by the use of PLC's to better control compactor functions. We NEVER use limit switches in any of our designs, because they're inferior; they fail, and we believe our customers deserve better. Our BUILT TUFF - BUILT RIGHT manufacturing process means that Ace Equipment Company Self-contained Compactors are built to exceed your expectations every day. We encourage you to compare our products against any other unit on the market for quality, productivity, and ROI.

### ACE EQUIPMENT COMPANY SELF-CONTAINED COMPACTOR FEATURES

- No Limit Switches Ever
- Slot & Tab Construction
- 3/16" Sidewalls **Standard**
- 1" Rail Liner **Standard**
- PLC Driven for Improved Productivity
- 33-to-66-Second Cycle Time
- In-House Build Power Unit
- American-Made Electric Motor
- American-Made Hydraulic Cylinders
- Available in Almost Any Size

# ACE



**EQUIPMENT COMPANY**  
BUILT TUFF. BUILT RIGHT.



# Ace Self-Contained Compactor Overview

## Perfect for:

- ✓ Grocery Stores
- ✓ Universities
- ✓ Hospitals
- ✓ Factories
- ✓ Casinos / Hotels

The Ace Equipment Company Self-Contained Compactor sets the bar as the most reliable compactor on the market. Every piece of this unit has been laser cut for precise tolerances *and* slot & tabbed for repeatable quality and performance. Ace container tippers can be added for additional safety and one-button automation for increased productivity. With three models to choose from and a variety of sizes, the Ace Equipment Company Self-Contained Compactor is the right choice for your operation. No one builds them like us - and no one supports them like us.



- ★ Ace Equipment compactors feature a one-piece seamless sidewall for longevity, corrosion resistance, and overall appearance.
- ★ Our one-piece seamless floor, sides and door are constructed of seamless 3/16" steel to remove the possibility of leaks!
- ★ Ace Equipment's power unit is 100% handcrafted at our Antigo, WI factory using only American-sourced motors and PLCs. No limit switches!
- ★ We can custom build 60" to 99" wide and 15 yard to 39-yard sizes
- ★ Compare our patent pending heavy duty door latch with any competitor's product on the market.
- ★ All Ace compactors feature American made hydraulic cylinders for unmatched performance and value.
- ★ Our 1" rail liner is twice as thick as our next competitor for longevity and durability!

## Installation Photos



# FEATURES & BENEFITS



# SPECIFICATIONS

## Self-Contained Compactor Specifications

Compactor Specs	E	EX	EX3
Clear Top (L x W)	40" x 60"	41-1/2" x 60"	60" x 60"
Capacity	2 cubic yard	2 cubic yard	3 cubic yard
Ram Face Size	23-5/8" X 59-1/8"	23-5/8" x 59-1/8"	23-5/8" x 59-1/8"
Rail Liner	1"	1"	1"
Cycle Time	57 seconds	37 seconds	66 seconds
Max Normal Force	45,160 lbs.	57,800 lbs.	68,000 lbs.
Max Ram Face Pressure	32.3 psi	41.4 psi	48 psi
Ram Penetration	6"	8.5"	12"
Electric Motor	3 hp	7.5 hp	10 hp
Electric Control Voltage	120 vac	120 vac	120 vac
Standard Controls	2-Push Button Station Start/Stop	2-Push Button Station Start/Stop	2-Push Button Station Start/Stop
Hydraulic Pump Capacity	3.8 gpm	10.5 gpm	10.5 gpm
Max Hydraulic Pressure	2300 psi	2300 psi	2100 psi
Hydraulic Cylinders	1	2	2
Bore	5	4	4.5
Rod	3.5	2	2.5



Patent Pending Door Latch

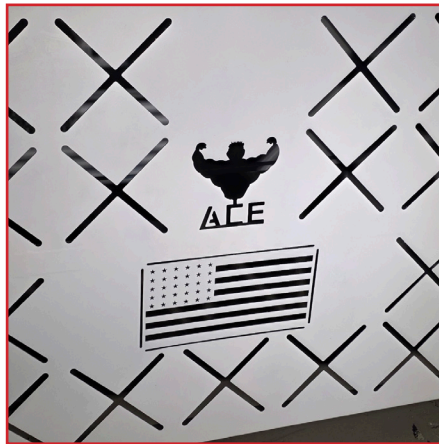

Custom Etching Available



Hand-Built Power Units



# DIMENSIONS

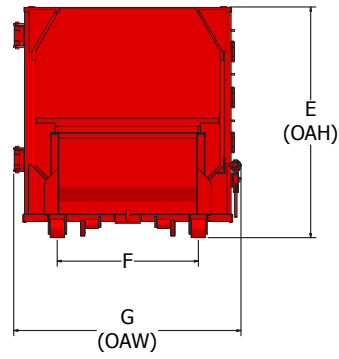
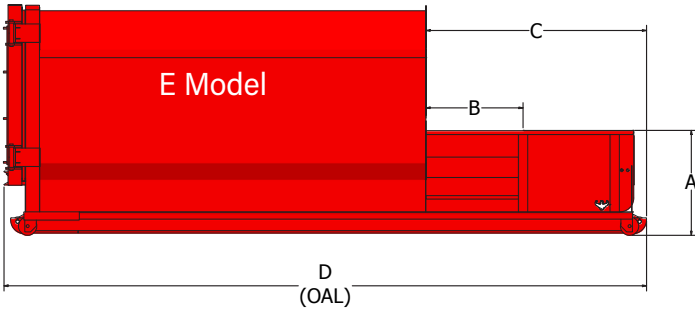

	15 CU YD	20 CU YD	25 CU YD	30 CU YD
A	45-1/2"	45-1/2"	45-1/2"	45-1/2"
B	40"	40"	40"	40"
C	96"	96"	96"	96"
D	207"	230"	254"	278"
E	100"	100"	100"	100"
F	61"	61"	61"	61"
G	98"	98"	98"	98"
WEIGHT	8,700 lbs	9,200 lbs	9,700 lbs	10,200 lbs

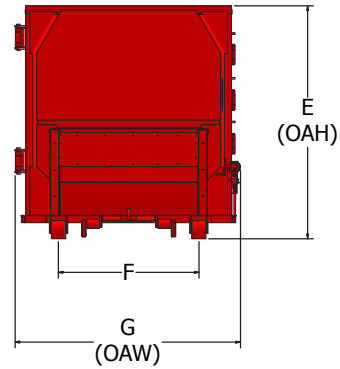
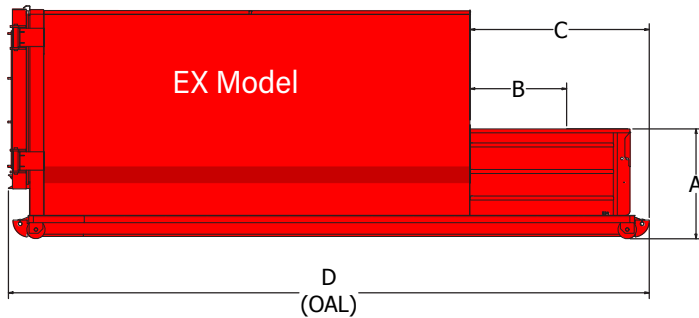

	15 CU YD	20 CU YD	25 CU YD	30 CU YD	34 CU YD	39 CU YD
A	48"	48"	48"	48"	48"	48"
B	41.5"	41.5"	41.5"	41.5"	41.5"	41.5"
C	78"	78"	78"	78"	78"	78"
D	171"	208"	214"	245"	278"	300"
E	100"	100"	100"	100"	100"	100"
F	61"	61"	61"	61"	61"	61"
G	98"	98"	98"	98"	98"	98"
WEIGHT	9,100 lbs	9,700 lbs	10,100 lbs	10,900 lbs	11,400 lbs	12,000 lbs

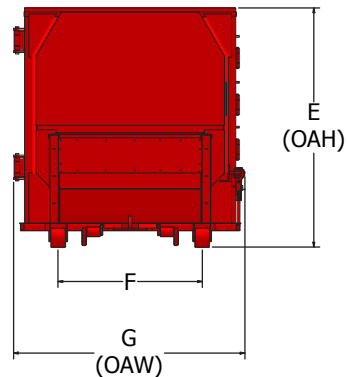
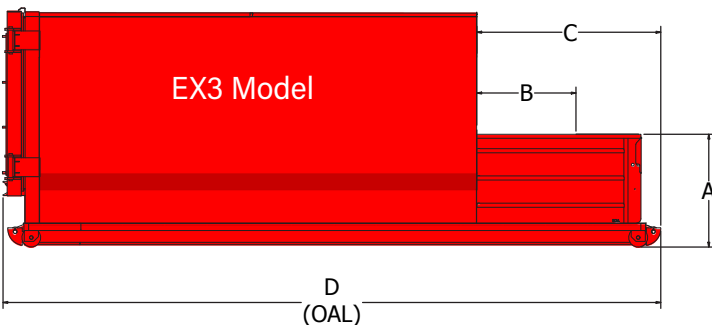

	15 CU YD	20 CU YD	25 CU YD	30 CU YD
A	48"	48"	48"	48"
B	60"	60"	60"	60"
C	102"	102"	102"	102"
D	207"	230"	254"	278"
E	100"	100"	100"	100"
F	61"	61"	61"	61"
G	98"	98"	98"	98"
WEIGHT	9,300 lbs	9,900 lbs	10,300 lbs	11,200 lbs



# SLOT & TAB PRECISION

## Why We Stand Out. Why It Matters.

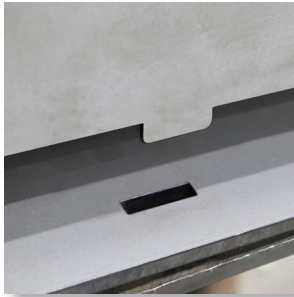

### OLD WORLD CRAFTSMANSHIP COMBINED WITH NEXT-GENERATION TECHNOLOGY

Ace Equipment Company, it starts with our 'Slot & Tab' assembly technique. Using the latest Mitsubishi computer-automated laser cutter; to achieve tolerances that no one else in the industry can offer. This allows us to deliver repeatable quality that ensures your Ace Equipment Company Transfer Compactor will continually exceed your expectations and deliver our customers with an ROI that no other manufacturer can match. Then we use a tongue & groove process to construct our floors to dramatically reduce the chance of debris getting behind the pack head or under the floor. No other compactor manufacturer builds their products like this, because it's more expensive and takes more time to manufacture. We don't operate that way - and we don't cut corners.



It's also reflected in our modern facility. One visit to our Antigo, Wisconsin factory and you'll understand. Like every piece of equipment we manufacture, our factory was purpose built to attract the finest artisans who work in a safe and inviting, well-lit facility enhanced with the latest technology to allow us to offer products constructed from 100% US-sourced steel, US-sourced hydraulic cylinders and hydraulic motors. No other compactor manufacturer can make that claim. Take a good look at any Ace Equipment Company product and you'll see that we've overbuilt it because we know you won't under use it. That is part of BUILT TUFF - BUILT RIGHT philosophy.

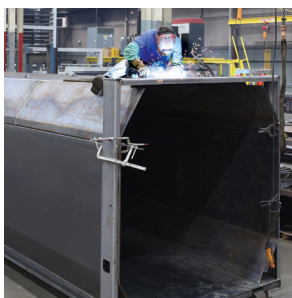

Ace Equipment Company • 810 Hudson Street • Antigo, WI 54409 • 715-627-2400  
[www.aceequipmentcompany.com](http://www.aceequipmentcompany.com) • [info@aceequipmentcompany.com](mailto:info@aceequipmentcompany.com)